

SOUTHEAST TEXAS CARBON STORAGE

September 17, 2024





MAKE A DIFFERENCE.

A HISTORY OF INNOVATION AND EXECUTION

Oxy formed 1PointFive to develop and deploy integrated carbon management solutions

- 50+ years of carbon management experience
- Experts in CO₂ transportation, utilization, and storage
- Decades of experience developing successful multi-billion-dollar projects
- 1PointFive will leverage Oxy's expertise in reservoir and carbon management



ZERO IN™





MAKE A DIFFERENCE.

Click here to view the video online: <https://www.setexas1pointfive.com/>





MONITORING TO ENSURE SAFETY

- Continuous observation of injection pressure and temperature data
- Monitoring wells
- Geophysical surveys
- Fluid sampling
- Soil and soil gas sampling
- Seismic studies and passive seismicity monitoring and recording

MAKE A DIFFERENCE.

THE CO₂ STORAGE SITE

Our team of experts continue to carefully evaluate the area to ensure safe secure CO₂ storage.

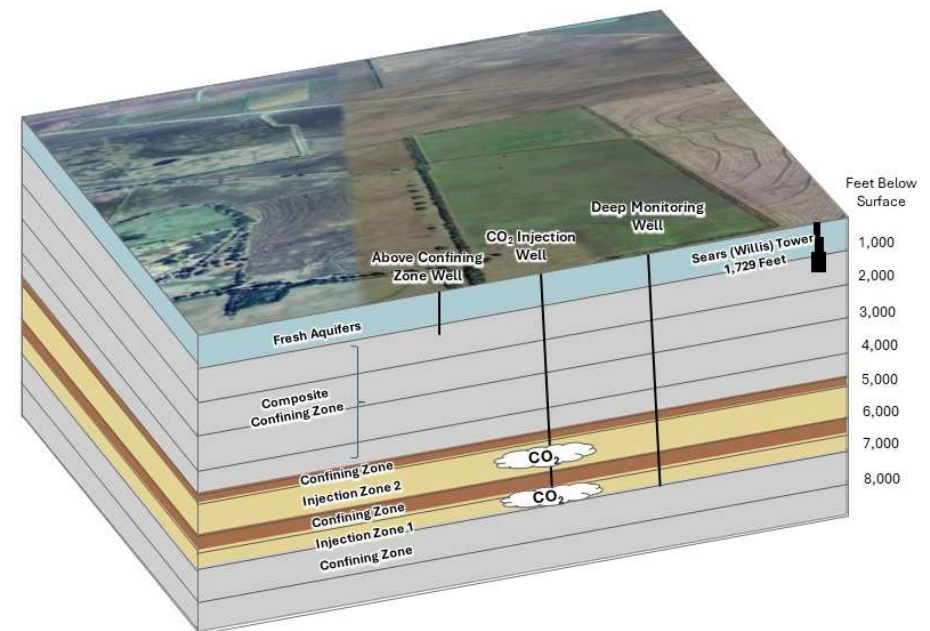



CO₂ STORAGE SAFETY

50+

YEARS OF EXPERIENCE

0

CO₂ SAFETY INCIDENTS



20M

METRIC TONS CO₂ SAFELY STORED ANNUALLY

2,500

MILES OF CO₂ PIPELINES

- Redundant systems are developed to provide failsafe controls and continuous monitoring
- We have robust emergency plans – that include temporary or permanent suspension of CO₂ injection
- Injection wells are engineered to protect underground sources of drinking water and to ensure safe secure long-term storage

MAKE A DIFFERENCE.

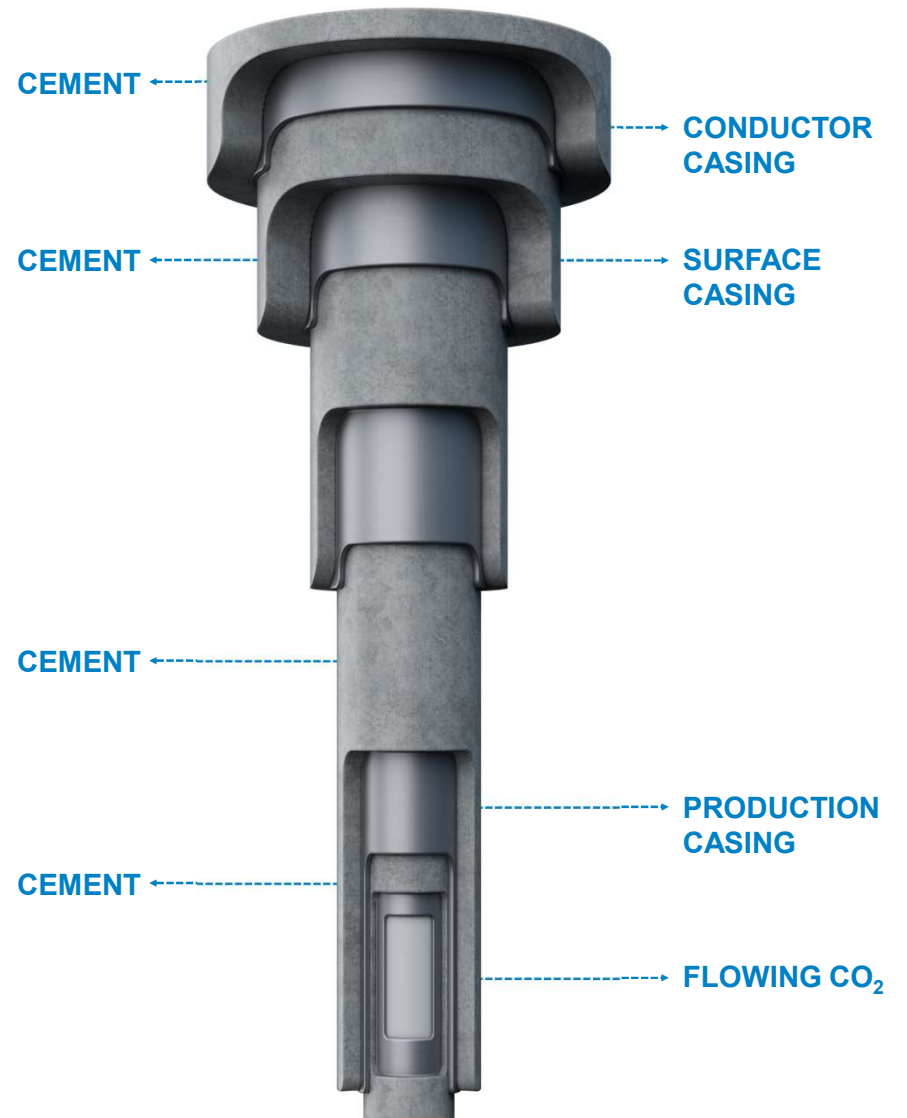

PROPOSED PROJECT LOCATION AND OVERVIEW

- Located northwest of Winnie, Texas
- Anticipated project components include:
 - ~ 5 - 7 Injection wells
 - ~ 7 - 11 Monitoring wells
 - ~ 2 - 4 Water production and disposal wells
 - 20+ Years of injection with long term post-injection site care

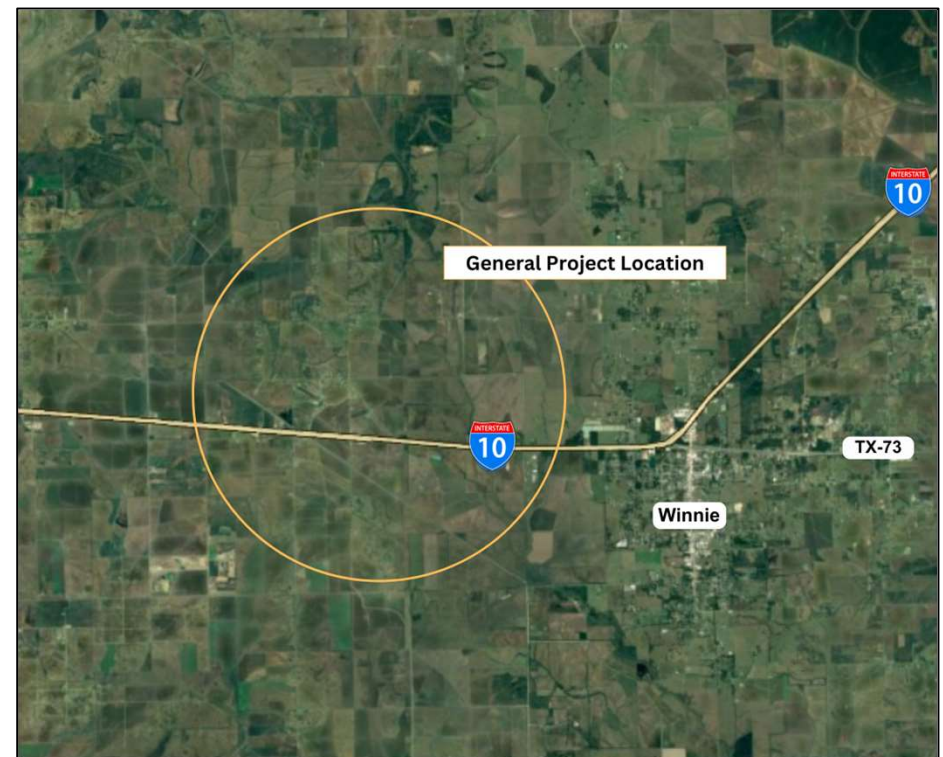

ESTIMATED PROJECT TIMELINES

This estimated project timeline is dependent upon permit approvals, weather, and rig availability. We will keep you up to date as the schedule changes.

Estimated Permitting Timeline

*Timelines are variable and subject to change



Estimated Project Timeline

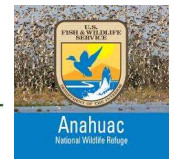
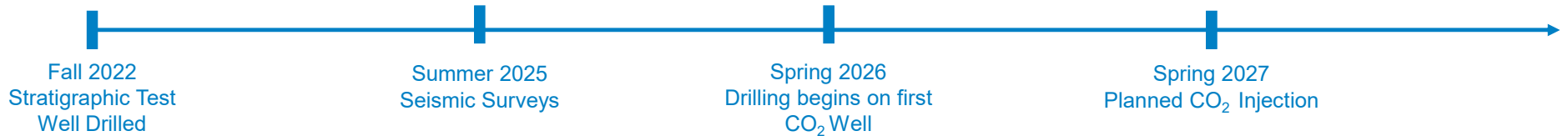

COMMUNITY PARTNERSHIPS

In addition to the direct benefits and increased economic activity, we are committed to creating mutually beneficial partnerships

CHARITABLE PARTNERSHIPS



Texas Rice Festival

- Golf tournament sponsor: 2023, 2024



Chambers County Children's Museum

- Exhibit sponsor: 2023, 2024



Support community first responders with donations for emergency response equipment, safety and rescue gear and priority line-of-duty resources.



2024 East Chambers Education Foundation Sponsor



TVE Fair & Rodeo BBQ Cookoff

- 2023 TVE Fair and Rodeo Youth Livestock Auction Block Sponsor
- 2024 TVE Fair and Rodeo BBQ Cookoff Title Sponsor



Marsh Fest

- Platinum Level Sponsor

LAND AGREEMENTS

- We have approached and/or signed all owners within the current project area. If you have questions about where your property is in relation to the project, you can meet our Land team at the posters after the presentation.
- The project is where the injection and monitoring operations are proposed to take place.
- Additional activities (ex: seismic studies) may take place outside the project area. Landowners outside the project may be approached to be a part of those activities/studies.

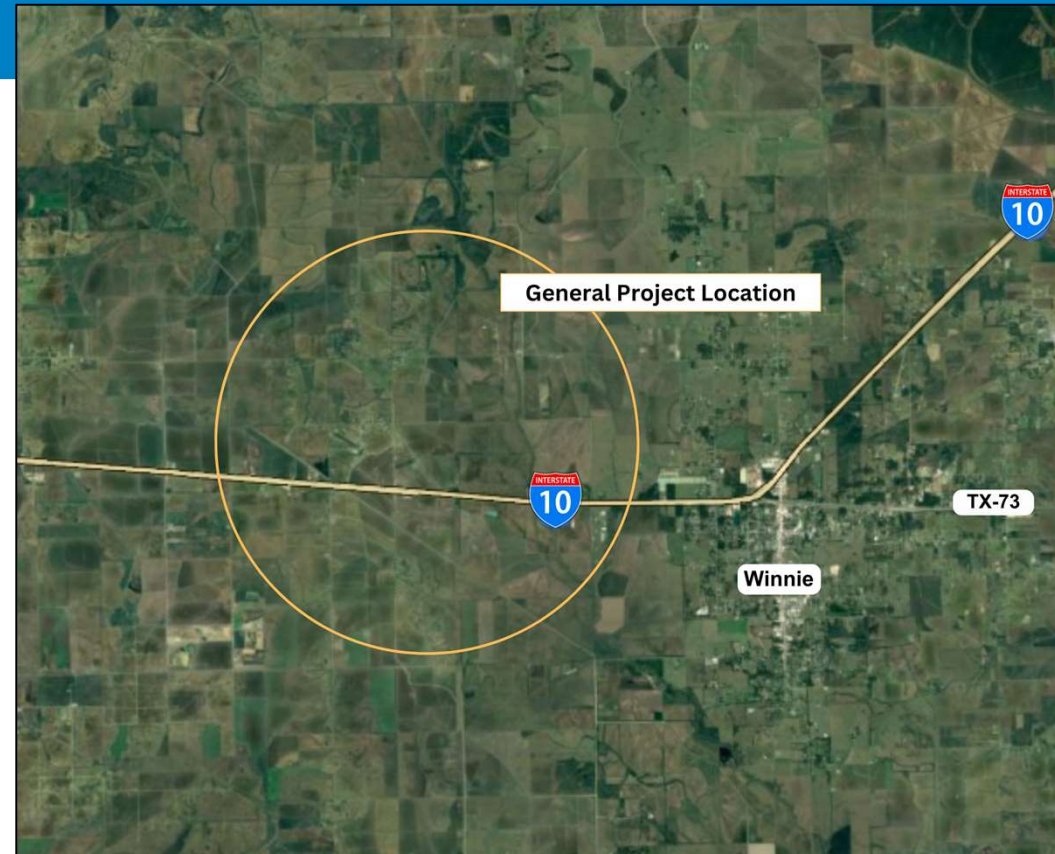

PERMIT PROCESS



In addition to the events and opportunities for the community to learn about the project and provide feedback, a critical part of the permitting process is that the draft permit will be published before approval, allowing the public to review and comment.

- CO₂ injection for sequestration is permitted by the EPA



- Information required for a permit application is extensive and includes:
 - Site characterization of injection and confining zones
 - Well casing and cementing program
 - Corrosion monitoring and prevention plan
 - Well integrity testing plan
 - Geophysical monitoring and fluid testing plan
 - Emergency and remedial response plan
 - Seismicity monitoring plan
 - Post-injection site care and closure plan
 - Long Term Financial responsibility



MAKE A DIFFERENCE.

STAKEHOLDER RELATIONS TEAM

Dedicated to communities since 2014

- Your feedback is important to us
- We engage with surrounding communities to share, listen and work with our internal teams to tailor operations to your community
- We are committed to transparency and sharing information proactively
- Our highest priority is to conduct our business in a manner that protects the health, safety, welfare, the environment and wildlife resources



Phone: 866.248.9051
Stakeholder@1PointFive.com
SETexas1PointFive.com



THANK YOU!

Phone: 866.248.9051
Stakeholder@1PointFive.com
SETexas1PointFive.com